





CRM 230

CURVADORA HIDRAULICA BASCULANTE PARA TRABALHOS HORIZONTAIS E VERTICAIS – PIRAMIDAL COM AVANÇO DO ROLO SUPERIOR

- CRM230HP
- CRM230HA
- CRM230HAM
- CRM230CNCH
- CRM230CNCHW
- CRM230HAIM
- CRM230IM
- CRM230IMW

Curvadora basculante adequada para trabalhos em posição horizontal ou vertical. O avanço hidráulico do rolo superior é hidraulicamente controlado.

				
mm 70x6 2-3/4" x 1/4"	mm 100x55 4" x 2-1/8"	Ø mm 70x3 Ø 2-3/4" x Ga11	Mm 70x30x3 2-3/4" x 1-1/4" x 1/8"	mm 50x50x4 2" x 2" x 5/32"

















Módulo de Resistência → W = 8 (a 11) cm³

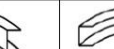

DADOS TÉCNICOS

DESCRIÇÃO	MODELO		
Ø dos eixos	Todos	mm	50
Potência do motor de Rotação	CRM230HP-CRM230HA	kW / RPM	3 / 10
	CRM230HAM-CRM230CNCH-CRM230CNCHW	kW / RPM	3 – 1,5 / 5 – 10
	CRM230HAIM-CRM230IM-CRM230IMW	kW / RPM	3 / 2,5 – 12
Potência do motor conjunto hidráulico translação	CRM230HP-CRM230HA	kW / Bar	1,5/180
	CRM230HAM-CRM230CNCH-CRM230CNCHW	kW / Bar	4 / 180
	CRM230HAIM-CRM230IM-CRM230IMW	kW / Bar	4 / 180
Med. – Pos.Horizontal	Todos	mm	1200x950x1150
Med. – Pos.Vertical	Todos	mm	950x1100x1500
Peso	Todos	Kg	530

Adequada a produções com perfilados de aço, PVC e alumínio, tubulares, ferros chatos, cantoneiras e tubos.

						
70 x 10mm 2-3/4" x 3/8"	120 x 15mm 4-3/4" x 5/8"	35mm 1-3/8"	50 x 4mm 2" x 5/32"	70 x 30 x 3mm 2-3/4" x 1-1/4" x 1/8"	90 x 30 x 4mm 3-1/2" x 1-1/4" x 5/32"	Ø 40mm Ø 1-1/2"
						
Ø 70 x 3mm Ø 2-3/4" Ga11	Ø60,3x3,9mm Ø 2"	60 x 8mm 2-3/8" x 3/8"	60 x 7mm 2-3/8" x 1/4"	70 x 8mm 2-3/4" x 3/8"	80 x 45mm 3" x 1-3/4"	65 x 42mm 2-1/2" x 1-1/2"
						
60 x 30mm 2-3/8" x 1/4"	70 x 6mm 2-3/4" x 1/4"	60 x 6mm 2-3/8" x 1/4"	100 x 55mm 4" x 2-1/8"			

A máquina pode ser equipada com oito soluções de comando diferentes. O código da máquina muda conforme a aplicação do tipo de controle.



CASORETTI

CASORETTI MÁQUINAS – Rua Jaguaribe 465 – 3º andar – Santa Cecília – São Paulo – SP – 01224-001
11 33333.6955 – 3333.1846 – 3333.1259 | 97605.9481 | E-mail: casoretti@casoretti.com.br